

SANYO



HYDRONIC PRODUCTS

**WATER CHILLERS
AIR-TO-WATER HEAT PUMPS**



SAVA





Less space, simple installation, weatherproofed construction

Water chillers and air-to water heat pumps are a new line of products specially designed to make installation simple and easy and reduce installation space.

The structure is compact, using limited floor space; this fact combined with low height and front access for installation works and maintenance, therefore reducing clearance needed on the other three sides, means that they can be easily used in any installation condition.

The built-in hydronic system, with water circulation pump and expansion tank, makes installer job easy: connection of supply and return water pipes and power supply cable is all it needs.

Designed and constructed for outdoor installation, all structures and components are adequately treated and protected against corrosion and weather.

Quality components, reliable operation, low noise

Hermetic **SCROLL** compressors, ensure reliable, efficient, vibration-free and low-noise operation. Compressors are insulated with a sound-proofing jacket.

Refrigerant-to-water, brazed plate heat exchangers, made in AISI316 stainless steel, are thermally insulated and protected against freezing and insufficient water flow.

Refrigerant-to-air heat exchanger, with copper tubes and aluminium plate fins, are generously sized and are protected by grilles with little pressure loss on the external surface. Axial flow fans with horizontal discharge are of proven efficiency and low noise.

Refrigerant and oil charge

Units are fully charged with environment-friendly refrigerant fluid and lubricant oil.

- **R410A** for model size **from 071 to 181**
- **R407C** for model size **from 201 to 802**

State-of-art control system

For model size from 071 to 401

A new generation of electronic controls with microprocessor offer the big advantage of eliminating the need of a large water storage tank, to avoid short-cycling of compressor, and allows operation with a reduced water volume in the system. By continuous analysis of compressor running time, the control system computes the best sequence of on-off cycles for compressor and adapts the leaving water temperature to the actual capacity required by the system. The integrated head pressure control allows operation with an outdoor air temperature as low as -10°C. The system also controls the operation of water circulation pump (cyclical start-up function, anti-freeze function).

For model size from 502 to 802

In addition to the equipment as above, these models use two hermetic **SCROLL** compressors with two completely separated refrigeration circuits and two-step control of capacity.

The built-in hydraulic module includes a buffer water tank of adequate size that always ensures a sufficient volume of water in the system.

Certified performance

Performance of **SCP-AR---E** chillers and **SCP-AR---EH** heat pumps are certified by EUROVENT, that verifies correctness of performance data given in this product specifications.

WATER CHILLERS serie SCP-AR---E

with air cooled condenser

MODEL RANGE



Page 6



Page 6

Unit size	081	111	151	171
Refrigerant type	R410A	R410A	R410A	R410A
Model	SCP-AR081E5 SCP-AR081E8	SCP-AR111E8	SCP-AR151E8	SCP-AR171E8
230V/1+N/50				
400V/3+N/50				
Cooling capacity kW	8.1	11.0	13.7	16.3
Basic features				
Built-in hydronic system	●	●	●	●
Buffer tank	accessory	accessory	accessory	accessory
Proportional head-pressure control	●	●	●	●
Dimensions HxWxD mm	735x1190x340	1235x1190x340	1235x1190x340	1235x1190x340
Accessories separately supplied				
Remote control	70250055	70250055	70250055	70250055
Interface MODBUS RS 485	70250056	70250056	70250056	70250056
Start-up kit single-phase unit	70550004	--	--	--
Set of water hoses	70600054	70600055	70600055	70600055
HP and LP gauges	--	--	--	--
Set anti-vibration pads	included	included	included	included
Insulated buffer tank 35 lt	70600118	70600118	70600118	70600118
External buffer tank 150 lt with 400W anti-freeze electric heater	--	--	--	--
External buffer tank 300 lt with 800W anti-freeze electric heater	--	--	--	--

4

AIR-TO-WATER HEAT PUMPS serie SCP-AR---EH

MODEL RANGE



Page 6



Page 6

Unit size	071	091	121	161	181
Refrigerant type	R410A	R410A	R410A	R410A	R410A
Model	SCP-AR071EH5	SCP-AR091EH5 SCP-AR091EH8	SCP-AR121EH5 SCP-AR121EH8	SCP-AR161EH8	SCP-AR181EH8
230V/1+N/50					
400V/3+N/50					
Cooling capacity kW	5.9	7.1	9.0	11.4	15.7
Heating capacity kW	7.3	9.0	12.7	15.2	19.6
Basic features					
Built-in hydronic system	●	●	●	●	●
Buffer tank	accessory	accessory	accessory	accessory	accessory
Proportional head-pressure control	●	●	●	●	●
Dimensions HxWxD mm	735x1190x340	735x1190x340	1235x1190x340	1235x1190x340	1235x1190x340
Accessories separately supplied					
Remote control	70250055	70250055	70250055	70250055	70250055
Interface MODBUS RS 485	70250056	70250056	70250056	70250056	70250056
Start-up kit single-phase unit	70550004	70550004	70550004	--	--
Set of water hoses	--	--	--	--	--
Electric heater for defrost water	70600054	70600054	70600055	70600055	70600055
HP and LP gauges	70200055	70200055	70200055	70200055	70200055
Set anti-vibration pads	--	--	--	--	--
Insulated buffer tank 35 lt	included	included	included	included	included
External buffer tank 150 lt with 400W anti-freeze electric heater	70600118	70600118	70600118	70600118	70600118
External buffer tank 300 lt with 800W anti-freeze electric heater	--	--	--	--	--



Page 10



Page 14

201	251	301	401	502	602	702	802
R407C	R407C	R407C	R407C	R407C	R407C	R407C	R407C
SCP-AR201E8	SCP-AR251E8	SCP-AR301E8	SCP-AR401E8	SCP-AR502E8	SCP-AR602E8	SCP-AR702E8	SCP-AR802E8
20.7	23.8	31.0	39.0	47.6	62.0	67.0	78.0
●	●	●	●	●	●	●	●
accessory	accessory	accessory	accessory	accessory	accessory	accessory	accessory
●	●	●	●	●	●	●	●
1175x975x1050	1175x975x1050	1175x975x1050	1425x975x1050	1175x1955x1050	1175x1955x1050	1175x1955x1050	1425x1955x1050
70250055	70250055	70250055	70250055	70250057	70250057	70250057	70250057
70250056	70250056	70250056	70250056	70250056	70250056	70250056	70250056
--	--	--	--	--	--	--	--
70600027	70600027	70600027	70600027	70600034	70600034	70600034	70600034
70970006	70970006	70970006	70970007	70970006 x 2pcs	70970006 x 2pcs	70970006 x 2pcs	70970007 x 2pcs
70600035	70600035	70600035	70600035	70600035	70600035	70600035	70600035
--	--	--	--	--	--	--	--
70600110	70600110	70600110	70600110	--	--	--	--
--	--	--	--	70600120	70600120	70600120	70600120



Page 10



Page 14

241	271	351	401	502	602	702	802
R407C	R407C	R407C	R407C	R407C	R407C	R407C	R407C
SCP-AR241EH8	SCP-AR271EH8	SCP-AR351EH8	SCP-AR401EH8	SCP-AR502EH8	SCP-AR602EH8	SCP-AR702EH8	SCP-AR802EH8
20.8	25.8	30.3	33.5	40.6	52.6	60.6	65.0
24.0	27.3	35.5	38.4	49.0	54.0	69.3	76.0
●	●	●	●	●	●	●	●
accessory	accessory	accessory	accessory	accessory	accessory	accessory	accessory
●	●	●	●	●	●	●	●
1175x975x1050	1175x975x1050	1175x975x1050	1425x975x1050	1175x1955x1050	1175x1955x1050	1175x1955x1050	1425x1955x1050
70250055	70250055	70250055	70250055	70250057	70250057	70250057	70250057
70250056	70250056	70250056	70250056	70250056	70250056	70250056	70250056
--	--	--	--	--	--	--	--
70600027	70600027	70600027	70600027	70600034	70600034	70600034	70600034
70970006	70970006	70970006	70970007	70970006 x 2pcs	70970006 x 2pcs	70970006 x 2pcs	70970007 x 2pcs
70600035	70600035	70600035	70600035	70600035	70600035	70600035	70600035
--	--	--	--	--	--	--	--
70600110	70600110	70600110	70600110	--	--	--	--
--	--	--	--	70600120	70600120	70600120	70600120

Specifications subject to change without notice

WATER CHILLERS & HEAT PUMPS Series SCP-AR---E/EH

WATER CHILLERS

SCP-AR081E5
 SCP-AR081E8
 SCP-AR111E8
 SCP-AR151E8
 SCP-AR171E8

HEAT PUMPS

SCP-AR071EH5
 SCP-AR091EH5
 SCP-AR091EH8
 SCP-AR0121EH5
 SCP-AR0121EH8
 SCP-AR0161EH8
 SCP-AR0181EH8

5,9 - 16,3 kW Nominal Cooling Capacity
 7,3 - 19,6 kW Nominal Heating Capacity



071...091

111...181

Standard equipment

Refrigeration system

- Hermetic compressor SCROLL type, with built-in overload protector, anti-vibration base, sound proofing jacket
- Thermostatic expansion valve
- Stainless steel brazed-plate heat exchanger
- 4-way reversing valve (heat-pump only)
- Liquid receiver
- Service connections for HP and LP reading and refrigerant refilling

Hydronic system

- Circulation pump with manual water flow regulator
- Air vent valve
- Safety valve
- Water pressure gauge
- Differential pressure switch

Electronic control: functions

- Digital display and selection keyboard
- On-Off
- Water temperature control
- Intelligent control of compressor and pump cycling and water temperature set-point
- Integrated head pressure control
- Automatic control of circulation pump for anti-freeze (heat-pump version only) and anti-sticking functions
- Defrost time control (heat-pump version only)
- Compressor and circulation pump operation hour counter
- Protection management: compressor HP and LP; no-cooling and no-heating (heat-pump version only), water flow, minimum water temperature

- Alarm management with event counter
- Display of: water temperature; set point; alarm codes
- Remote ON-OFF
- Remote HEAT-COOL changeover (heat-pump version only)

Electric board

- Contactor
- Phase sequence tester (121EH8 and 161EH8 model)
- Printed circuit board
- Terminal strip

Included accessories

- Built-in display-keyboard controller
- Water strainer (separately supplied)
- Water pressure gauge
- Anti-vibration pads (2pcs)
- Drain elbow pipe

Separately supplied accessories

- Remote control module with keyboard and digital display
- Communication interface MODBUS RS485
- Start-up kit for single-phase unit
- Electric heater for defrost water (heat-pump version only)
- Set of water hoses
- Insulated buffer tank 35 lt

WATER CHILLERS

NOMINAL PERFORMANCE & PHYSICAL DATA

MODEL		SCP-AR081E5	SCP-AR081E8	SCP-AR111E8	SCP-AR151E8	SCP-AR171E8
Performance						
		Cooling	Cooling	Cooling	Cooling	Cooling
Capacity	kW	8.1	8.11	11.0	13.7	16.3
Absorbed power	kW	3.63	3.56	4.42	5.27	6.27
Absorbed current	A	15.2	7.2	10.5	11.2	14.9
E.E.R.	W/W	2.23	2.28	2.49	2.6	2.60
ESEER	W/W	2.44	2.50	2.76	2.90	2.86
Water flow	l/sec	0.39	0.39	0.53	0.65	0.8
Available pump head	kPa	42	42	55	68	75
Main power supply	V/Ph/Hz	230/1+N/50	400/3+N/50		400/3+N/50	
Expansion tank volume	l		2		2	
Hydraulic connection diameter	inch		3/4" Male		1" Male	
Water content of hydraulic circuit	l		2.2		2.8	3.0
Compressor	n./type			1/Hermetic SCROLL		
Refrigerant circuits	n.			1		
Refrigerant	type			R410A		
Total refrigerant charge	kg		1.8	3.1	3.3	3.5
Fan	n./type/Ømm		1/axial flow horizontal discharge/460		2/axial flow horizontal discharge/460	
Fan speed	rpm			770		
Air flow	m³/h		2800	5000	5000	5000
Sound levels						
Sound power level	dB-A		65		67	
Sound pressure level	dB-A		37		39	
Electrical data						
Main power supply	V/Ph/Hz	230/1+N/50			400/3+N/50	
Voltage permissible limit	V		207-253		360-440	
Maximum absorbed power (*)	kW		4.8	4.3	6.1	7.1
Maximum absorbed current (*)	A		26	11	14	17
Start-up current/with start-up kit	A		97/44	48	64	74
System water content						
Minimum water content (**)	l		30		40	50
Maximum water content (***)	l				90	60
Dimensions & Weights						
HxWxD net	mm		735 x 1190 x 340	1235 x 1190 x 340	1235 x 1190 x 340	1235 x 1190 x 340
Weight net	kg		87	110	122	135

(*) Within the operatin limits

(**) If water content of the system is below minimum the installation of a storage tank is necessary

(***) If the water volume of the system is above the maximum, an additional expansion tank is required

ESEER: European Seasonal Energy Efficiency Ratio published by Eurovent

Specifications subject to change without notice

Nominal conditions

- Outdoor air temperature 35°C
- Inlet water temperature 12°C
- Outlet water temperature 7°C

Sound pressure level

- Unit installed outdoor (free field)
- Measuring distance 10 m
- Outdoor air temperature 35°C

OPERATING LIMITS

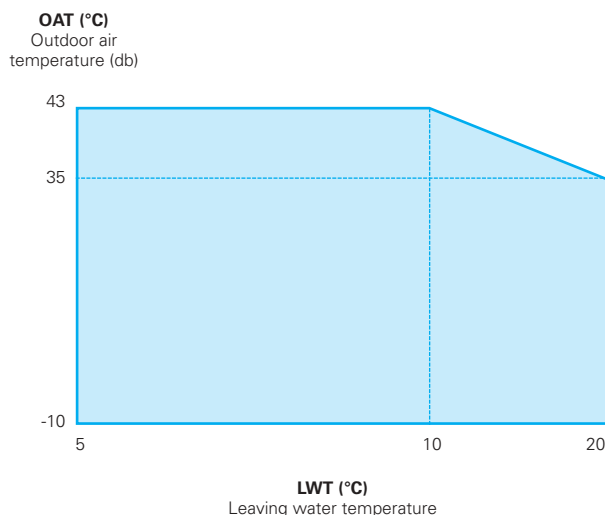

AIR-TO-WATER HEAT PUMPS

NOMINAL PERFORMANCE & PHYSICAL DATA

MODEL	Performance	SCP-AR071EH5		SCP-AR091EH5		SCP-AR091EH8		SCP-AR121EH5		SCP-AR121EH8		SCP-AR161EH8		SCP-AR181EH8			
		Cooling	Heating	Cooling	Heating	Cooling	Heating	Cooling	Heating	Cooling	Heating	Cooling	Heating	Cooling	Heating		
Capacity	kW	5.9	7.3	7.1	9.0	7.2	9.1	8.5	10.65	9.0	12.7	11.4	15.2	15.7	19.6		
Absorbed power	kW	2.61	2.56	3.14	3.16	3.09	3.11	3.31	3.48	3.73	3.94	4.98	4.82	6.88	6.32		
Absorbed current	A	12.2	12.8	11.4	15.0	6.1	6.1	16.1	16.7	7.2	7.5	10.2	9.9	15.2	14.6		
E.E.R./C.O.P.	W/W	2.26	2.85	2.26	2.85	2.33	2.92	2.57	3.06	2.41	3.22	2.29	3.15	2.28	3.1		
ESEER	W/W	na	--	2.53	--	na	--	2.82	--	2.47	--	2.51	--	2.66	--		
Water flow	l/sec	0.28	0.34	0.34	0.44	0.34	0.43	0.41	0.52	0.42	0.6	0.55	0.75	0.75	0.94		
Available pump head	kPa	64	57	59	47	59	47	82	66	80	53	84	68	78	59		
Main power supply	V/Ph/Hz	230/1+N/50		230/1+N/50		400/3+N/50		230/1+N/50		400/3+N/50		400/3+N/50		400/3+N/50			
Expansion tank volume	l	2		2		2		2		2		2		2			
Hydraulic connection diameter	inch					3/4" Male				1" Male							
Water content of hydraulic circuit	l					2.6				2.8							
Compressor	n./type	1/Hermetic SCROLL															
Refrigerant circuits	n.	1															
Refrigerant	type	R410A															
Total refrigerant charge	kg	na		2.1		3.5		3.5		3.7		3.8		3.5			
Fan	n./type/Ømm	1/axial flow horizontal discharge/460															
Fan speed	rpm					770				5000				1090			
Air flow	m³/h	2800		2800				5000		5000		7700					
Sound levels																	
Sound power level	dB-A					65				67				73			
Sound pressure level	dB-A					37				39				45			
Electrical data																	
Main power supply	V/Ph/Hz	230/1+N/50		230/1+N/50		400/3+N/50		230/1+N/50		400/3+N/50		400/3+N/50		400/3+N/50			
Voltage permissible limit	V	207-253		207-253		360-440		207-253		360-440		360-440		360-440			
Maximum absorbed power (*)	kW	3.25		4.0		4.0		4.7		5.1		7.0		9.2			
Maximum absorbed current (*)	A	16		18.2		7.5		21.3		9.0		12.7		18.0			
Start-up current/with start-up kit	A	77/40		86/42		na		89/43		56		63		101			
System water content																	
Minimum water content (**)	l	30		40		40		50		50		60		60			
Maximum water content (***)	l	90															
Dimensions & Weights																	
HxVxD net	mm					735x1190x340				1235x1190x340				1235x1190x340			
Weight net	kg	95		98				128		133		138					

(*) Within the operatin limits

(**) If water content of the system is below minimum the installation of a storage tank is necessary

(***) If the water volume of the system is above the maximum, an additional expansion tank is required

ESEER: European Seasonal Energy Efficiency Ratio published by Eurovent

Specifications subject to change without notice
na: data not available at the time of publication

Nominal conditions

	Cooling	Heating	Sound pressure level
Outdoor air temperature: (db/wb)	35°C (db)	7/6°C	• Unit installed outdoor (free field)
Inlet water temperature	12°C	40°C	• Measuring distance 10 m
Outlet water temperature	7°C	45°C	• Outdoor air temperature 35°C

OPERATING LIMITS

Cooling

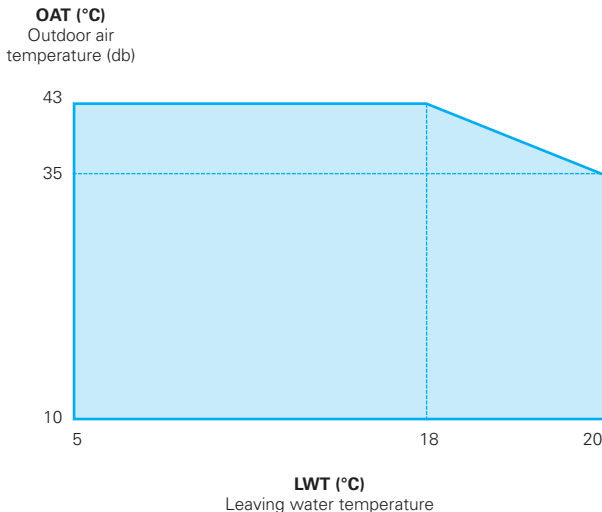

Heating

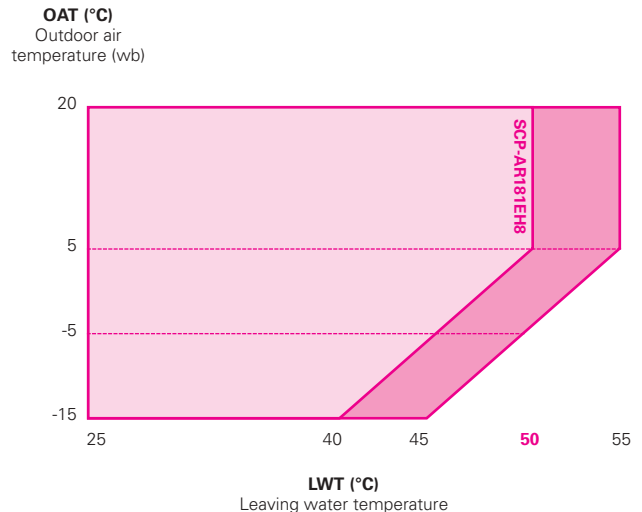

WATER CHILLERS & HEAT PUMPS

DIMENSIONS AND MINIMUM CLEARANCE

SCP-AR071EH5 - SCP-AR091EH5/EH8

- 1 water inlet 3/4" male air vent
- 2 water outlet 3/4" male
- 3 filling and drainage water circuit 1/2" male
- 4 electric cables entry

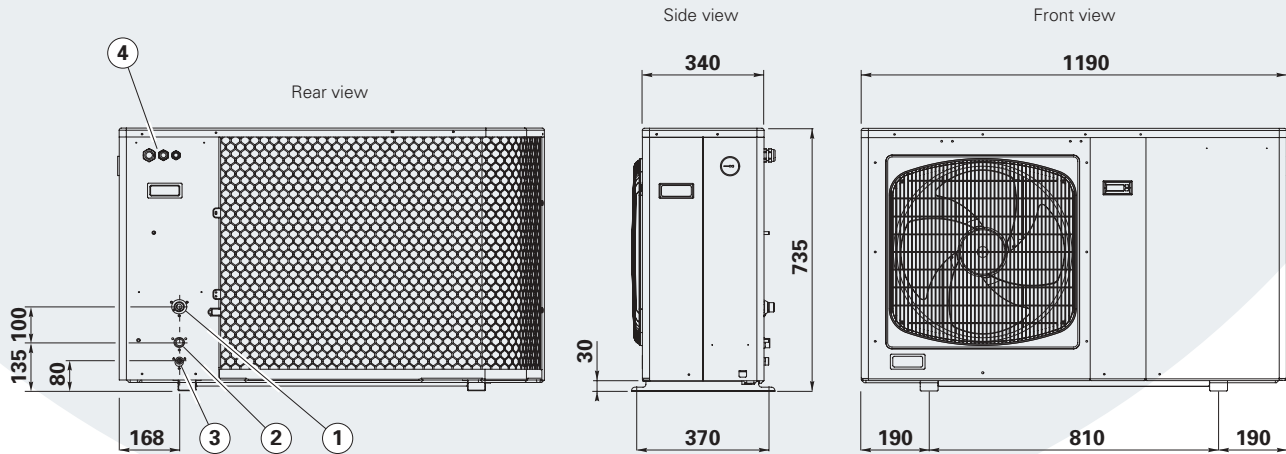

SCP-AR081E5/E8

- 1 water outlet 3/4" male air vent
- 2 water inlet 3/4" male
- 3 filling and drainage water circuit 1/2" male
- 4 electric cables entry

SCP-AR121EH5/EH8 - SCP-AR161EH8 SCP-AR181EH8

- 1 water inlet 1" male air vent
- 2 water outlet 1" male
- 3 filling and drainage water circuit 1/2" male
- 4 electric cables entry

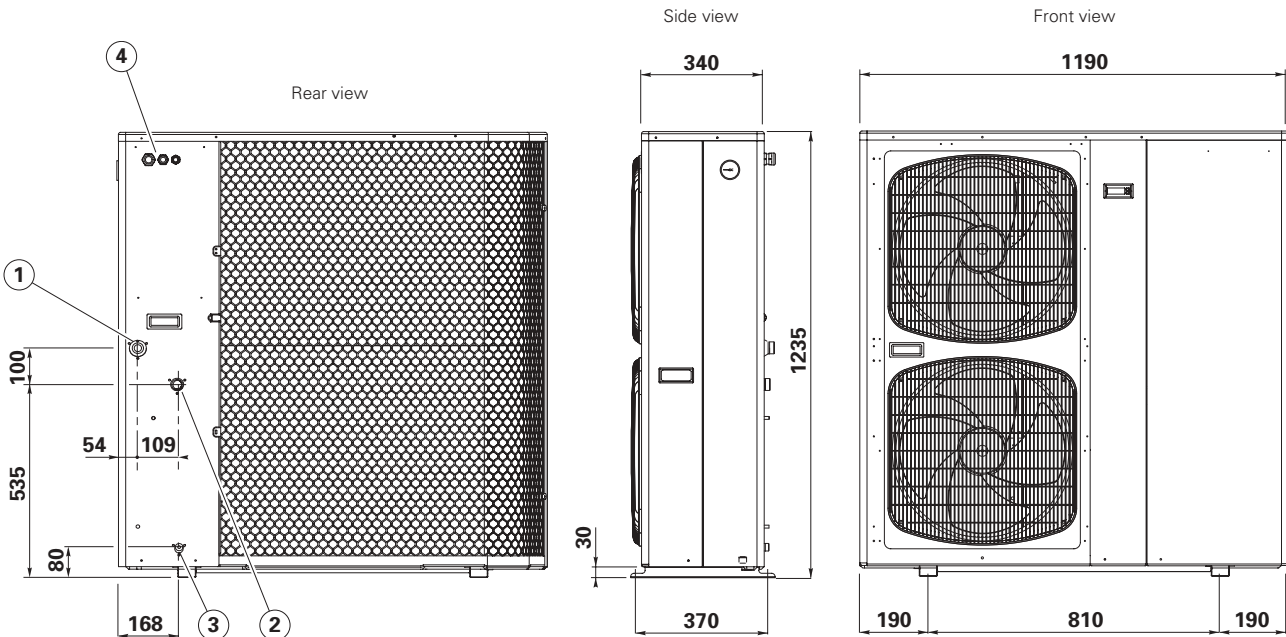

SCP-AR111E5/E8 - SCP-AR151E8 SCP-AR171E8

- 1 water inlet 1" male air vent
- 2 water outlet 1" male
- 3 filling and drainage water circuit 1/2" male
- 4 electric cables entry

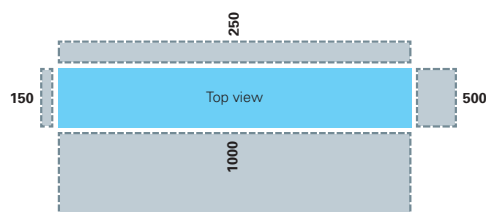

Minimum clearance for operation and maintenance (for all type)

WATER CHILLERS & HEAT PUMPS Series SCP-AR---E/EH

WATER CHILLERS

SCP-AR201E8
 SCP-AR251E8
 SCP-AR301E8
 SCP-AR401E8

HEAT PUMPS

SCP-AR241EH8
 SCP-AR271EH8
 SCP-AR351EH8
 SCP-AR401EH8

20,7 - 39,0 kW Nominal Cooling Capacity
 24,0 - 38,4 kW Nominal Heating Capacity



Standard equipment

Refrigeration system

- Hermetic compressor SCROLL type, with built-in overload protector, anti-vibration base, sound proofing jacket
- Thermostatic expansion valve (2 valves for heat pump versions)
- Stainless steel brazed-plate heat exchanger
- 4-way reversing valve (heat-pump only)
- Filter drier
- Liquid receiver
- Service connections for HP and LP reading and refrigerant refilling

Hydronic system

- Circulation pump, with flow regulating valve and shut-off valves (2)
- Air vent valve
- Safety valve
- Water pressure gauge
- Expansion tank
- Differential pressure switch

Electronic control: functions

- Digital display and selection keyboard
- On-Off
- Water temperature control
- Intelligent control of compressor and pump cycling and water temperature set-point
- Integrated head pressure control
- Automatic control of circulation pump for anti-freeze (heat-pump version only) and anti-sticking functions
- Defrost time control (heat-pump version only)
- Compressor and circulation pump operation hour counter

- Protection management: compressor HP and LP; no-cooling and no-heating (heat-pump version only), water flow, minimum water temperature
- Alarm management with event counter
- Display of: water temperature; set point; alarm codes
- Remote ON-OFF
- Remote HEAT-COOL changeover (heat-pump version only)

Electric board

- Main switch
- Contactor
- Phase sequence tester
- Printed circuit board
- Terminal strip

Included accessories

- Built-in display-keyboard controller
- Water strainer (separately supplied)
- Main switch

Separately supplied accessories

- Remote control module with keyboard and digital display
- Communication interface MODBUS RS485
- HP and LP gauges
- Set of water hoses
- Set of anti-vibration pads (4)
- External buffer tank 150lt with 400W anti-freeze electric heater

WATER CHILLERS

NOMINAL PERFORMANCE & PHYSICAL DATA

MODEL		SCP-AR201E8	SCP-AR251E8	SCP-AR301E8	SCP-AR401E8
Performance					
		Cooling	Cooling	Cooling	Cooling
Capacity	kW	20.7	23.8	31.0	39.0
Absorbed power	kW	8.3	10.4	13.4	14.8
Absorbed current	A	18.0	20.7	24.7	28.3
E.E.R.	W/W	2.49	2.29	2.31	2.64
ESEER	W/W	2.97	2.73	2.62	2.81
Water flow	l/sec	0.99	1.16	1.48	1.87
Available pump head	kPa	210	170	200	135
Main power supply	V/Ph/Hz			400/3+N/50	
Expansion tank volume	l			8.0	
Hydraulic connection diameter	inch			1 1/4 Male	
Water content of hydraulic circuit	l	10.7	11.0	11.5	11.7
Compressor	n./type			1/Hermetic SCROLL	
Refrigerant circuits	n.			1	
Refrigerant	type			R407C	
Total refrigerant charge	kg	6.5	7.3	8.0	12.5
Fan	n./type/Ømm			1/axial flow vertical discharge/760	
Fan speed	rpm	620			660
Air flow	m³/h	9800			11000
Sound levels					
Sound power level	dB-A	79	78	80	82
Sound pressure level	dB-A	51	50	52	54
Electrical data					
Main power supply	V/Ph/Hz			400/3+N/50	
Voltage permissible limit	V			360-440	
Maximum absorbed power (*)	kW	11.85	12.9	16.5	18.8
Maximum absorbed current (*)	A	22.5	24.3	31.6	35.8
Start-up current	A	145	145	150	190
System water content					
Minimum water content (**)	l	70	70	95	120
Maximum water content (***)	l			300	
Dimensions & Weights					
HxWxD unit	mm	1175 x 975 x 1050	1175 x 975 x 1050	1175 x 975 x 1050	1425 x 975 x 1050
Weight unit	kg	292	295	317	353
HxWxD buffer tank (accessory)	mm	611 x 975 x 1050	611 x 975 x 1050	611 x 975 x 1050	611 x 975 x 1050
Weight buffer tank (accessory)	kg	112	112	112	112

(*) Within the operatin limits

(**) If water content of the system is below minimum the installation of a storage tank is necessary

(***) If the water volume of the system is above the maximum, an additional expansion tank is required

ESEER: European Seasonal Energy Efficiency Ratio published by Eurovent

Specifications subject to change without notice

Nominal conditions		Sound pressure level	
• Outdoor air temperature	35°C	• Unit installed outdoor (free field)	
• Inlet water temperature	12°C	• Measuring distance	10 m
• Outlet water temperature	7°C	• Outdoor air temperature	35°C

OPERATING LIMITS

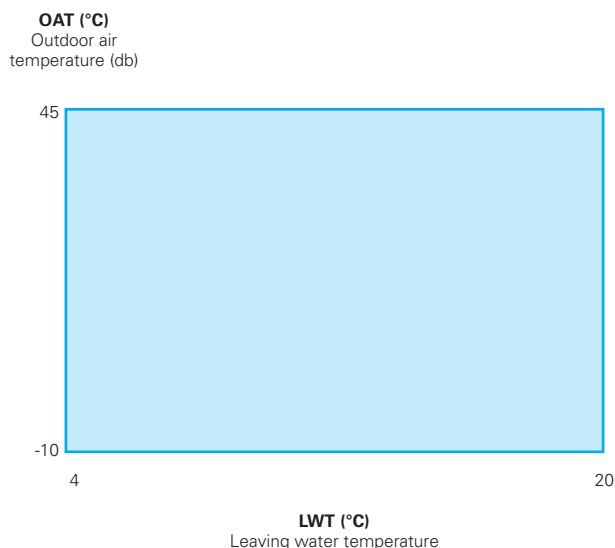

AIR-TO-WATER HEAT PUMPS

NOMINAL PERFORMANCE & PHYSICAL DATA

MODEL	SCP-AR241EH8		SCP-AR271EH8		SCP-AR351EH8		SCP-AR401EH8		
	Cooling	Heating	Cooling	Heating	Cooling	Heating	Cooling	Heating	
Performance									
Capacity	kW	20.8	24.0	25.8	27.3	30.3	35.5	33.5	38.4
Absorbed power	kW	8.85	9.0	9.77	10.4	13.55	13.55	14.55	14.75
Absorbed current	A	18.6	19.9	20.0	20.9	27.3	25.0	29.3	28.7
E.E.R./C.O.P.	W/W	2.35	2.67	2.66	2.63	2.24	2.62	2.30	2.60
ESEER	W/W	2.78	--	2.49	--	2.45	--	2.72	--
Water flow	l/sec	0.97	1.17	1.25	1.30	1.45	1.65	1.68	2.0
Available pump head	kPa	215	185	160	145	200	140	165	95
Main power supply	V/Ph/Hz	400/3+N/50							
Expansion tank volume	l	8							
Hydraulic connection diameter	inch	1 1/4 Male							
Water content of hydraulic circuit	l	10.7		11		11.5		11.9	
Compressor	n./type	1/Hermetic SCROLL							
Refrigerant circuits	n.	1							
Refrigerant	type	R407C							
Total refrigerant charge	kg	8		9		9.5		12.5	
Fan	n./type/Ømm	1/axial flow vertical discharge/760							
Fan speed	rpm	620				660			
Air flow	m³/h	9800				11000			
Sound levels									
Sound power level	dB-A	79		78		80		82	
Sound pressure level	dB-A	51		50		52		54	
Electrical data									
Main power supply	V/Ph/Hz	400/3+N/50							
Voltage permissible limit	V	360-440							
Maximum absorbed power(*)	kW	11.8		13.6		18.4		20.0	
Maximum absorbed current (*)	A	22.7		25.8		34.0		38.7	
Start-up current	A	145				150			
System water content									
Minimum water content (**)	l	80		90		120		130	
Maximum water content (***)	l	250							
Dimensions & Weights									
HxWxD unit	mm	1175 x 975 x 1050		1175 x 975 x 1050		1175 x 975 x 1050		1425 x 975 x 1050	
Weight unit	kg	303		305		327		363	
HxWxD buffer tank (accessory)	mm	611 x 975 x 1050		611 x 975 x 1050		611 x 975 x 1050		611 x 975 x 1050	
Weight buffer tank (accessory)	kg	112		112		112		112	

(*) Within the operatin limits

(**) If water content of the system is below minimum the installation of a storage tank is necessary

(***) If the water volume of the system is above the maximum, an additional expansion tank is required

ESEER: European Seasonal Energy Efficiency Ratio published by Eurovent

Specifications subject to change without notice

Nominal conditions	Cooling		Heating		Sound pressure level
	35°C (db)	7/6°C	12°C	40°C	
• Outdoor air temperature (db/wb)	35°C (db)	7/6°C	12°C	40°C	• Unit installed outdoor (free field)
• Inlet water temperature	12°C	40°C	7°C	45°C	• Measuring distance
• Outlet water temperature	7°C	45°C			• Outdoor air temperature
					10 m
					35°C

OPERATING LIMITS

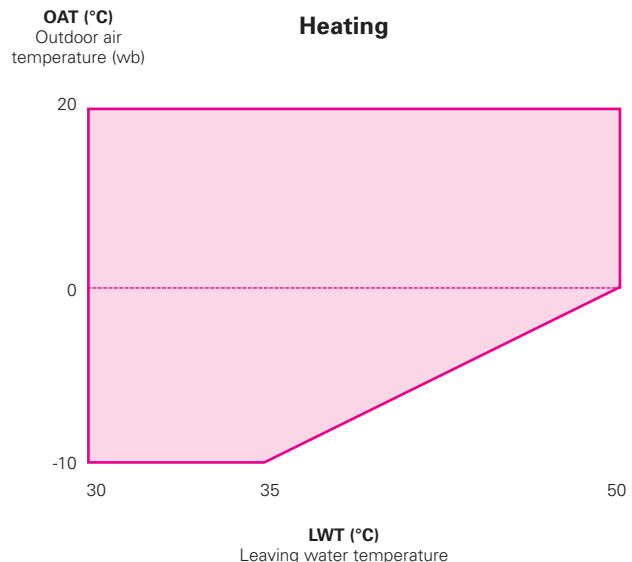
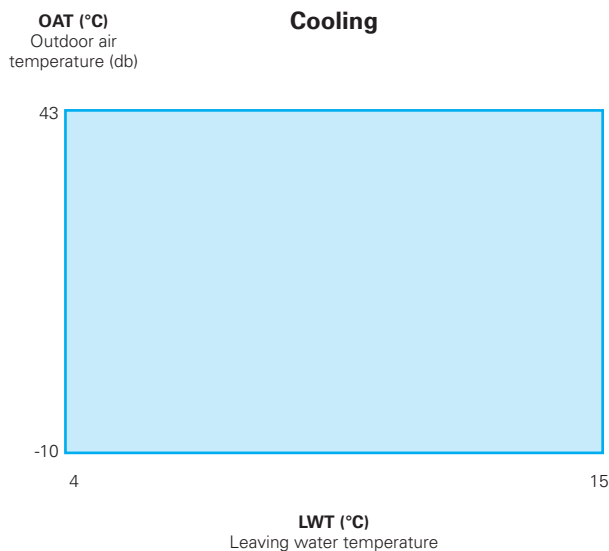

WATER CHILLERS & HEAT PUMPS

DIMENSIONS AND MINIMUM CLEARANCE

Dimensions (in mm) are given for standard units without options.
General tolerance ± 10 mm.

WATER CHILLERS

SCP-AR201E8
SCP-AR251E8
SCP-AR301E8
SCP-AR401E8

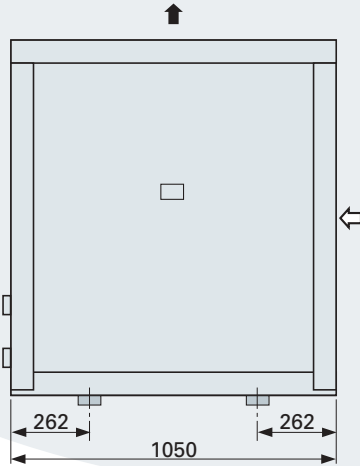

HEAT PUMPS

SCP-AR241E8
SCP-AR271E8
SCP-AR351E8
SCP-AR401E8

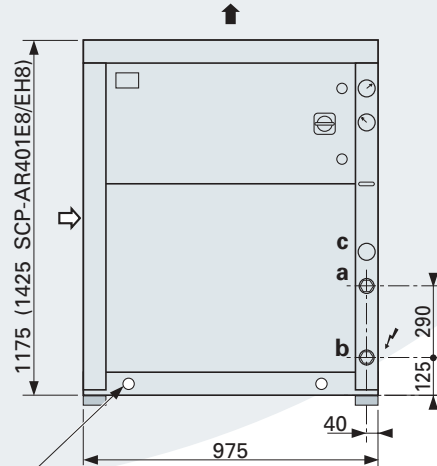

4 \varnothing 22.5 mm holes for sling attachment

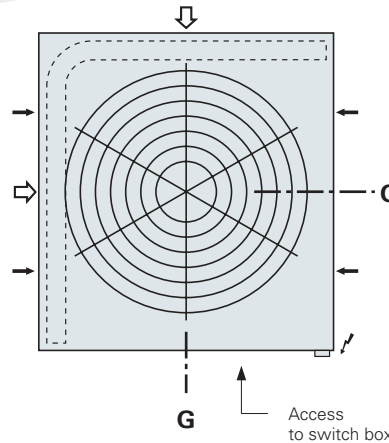

Minimum clearance (mm)

A = could be nil

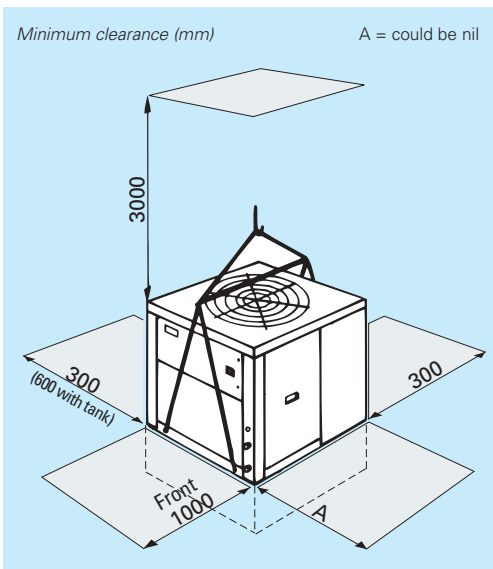

With 150-litre buffer tank (70600110 accessory)

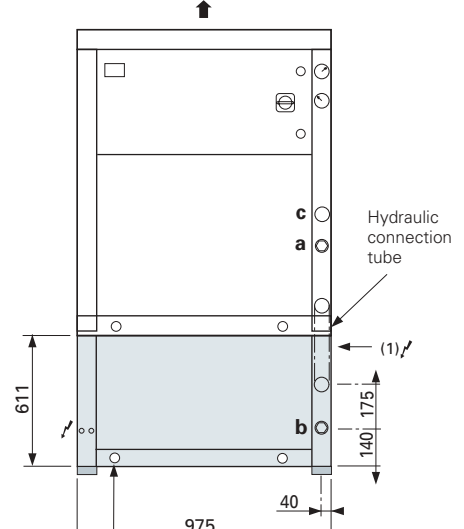
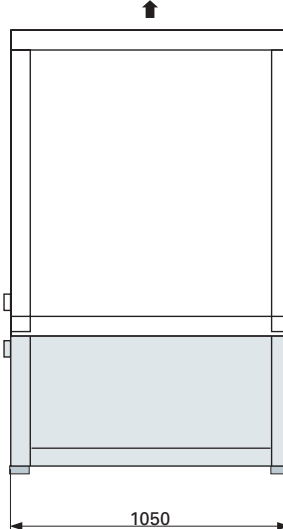

4 \varnothing 22.5 mm holes for passing slings for handling the tank only

- Condenser air discharge
- Condenser air suction
- a** Water inlet connection
- b** Water outlet connection
- c** HP and LP hose entry
- Power supply
- Power supply (antifreeze)
- Location of the 4 anti-vibration pads (optional) (100 x 100 x 25 mm) under girders
- G** Centre of gravity

Buffer tank

WATER CHILLERS & HEAT PUMPS Series SCP-AR---E/EH

WATER CHILLERS

SCP-AR502E8
 SCP-AR602E8
 SCP-AR702E8
 SCP-AR802E8

HEAT PUMPS

SCP-AR502EH8
 SCP-AR602EH8
 SCP-AR702EH8
 SCP-AR802EH8

47,6 - 78,0 kW Nominal Cooling Capacity
 49,0 - 76,0 kW Nominal Heating Capacity



Standard equipment

Refrigeration system

(2 separated circuits for 2-step control)

- 2 hermetic compressors SCROLL type, with built-in over-load protector, anti-vibration base, sound proofing jacket
- 2 thermostatic expansion valves
- 2 4-way reversing valve (heat pump only)
- 2 filter driers
- 2 refrigerant-to-air heat exchangers
- 2 refrigerant-to-water, brazed plate heat exchangers
- 2 thermostatically controlled two-speed axial flow fans

Hydronic system

- Circulation pump, with with flow regulating valve and shut-off valves (2)
- Water filling valve
- Air vent valve
- Safety valve
- Drain valve
- Water pressure gauge
- Water circulation controlled by differential pressure switch
- Expansion tank

Electronic control: functions

- Digital display and selection keyboard
- On-Off
- Water temperature control
- Intelligent control of compressor and pump cycling and water temperature set-point
- Integrated head pressure control
- Automatic control of circulation pump for anti-freeze (heat-pump version only) and anti-sticking functions
- Defrost time control (heat-pump version only)
- Compressor and circulation pump operation hour counter
- Protection management: compressor HP and LP; no-cooling and no-heating (heat-pump version only), water flow, minimum water temperature

- Alarm management with event counter
- Display of: water temperature; set point; alarm codes
- Remote ON-OFF
- Remote HEAT-COOL changeover (heat-pump version only)

Electric board

- Main switch
- Contactor
- Phase sequence tester
- Printed circuit board
- Water flow protection
- Terminal strip

Included accessories

- Built-in display-keyboard controller
- Water strainer (separately supplied)
- Main switch

Included accessories

- Remote control module with keyboard and digital display
- Communication interface MODBUS RS485
- HP and LP gauges
- Set of water hoses
- Set of anti-vibration pads (4)
- External buffer tank 300lt with 800W anti-freeze electric heater

WATER CHILLERS

NOMINAL PERFORMANCE & PHYSICAL DATA

MODEL		SCP-AR502E8	SCP-AR602E8	SCP-AR702E8	SCP-AR802E8
Performance					
		Cooling	Cooling	Cooling	Cooling
Capacity	kW	47.6	62.0	67.0	78.0
Absorbed power	kW	20.6	26.4	28.8	29.4
Absorbed current	A	38.7	47.7	54.0	55.5
E.E.R.	W/W	2.31	2.35	2.33	2.65
ESEER	W/W	2.74	2.65	2.56	2.94
Water flow	l/sec	2.28	2.96	3.2	3.73
Available pump head	kPa	220	160	180	90
Main power supply	V/Ph/Hz	400/3+N/50			
Expansion tank volume	l	18			
Hydraulic connection diameter	inch	1 1/2 Male			
Compressor	n./type	2/Hermetic SCROLL			
Refrigerant circuits	n.	2			
Refrigerant	type	R407C			
Total refrigerant charge	kg	2 x 7.25	2 x 8.0	2 x 9.0	2 x 12.5
Fan	n./type/Ømm	2/axial flow vertical discharge/760			
Fan speed	rpm	620	660	660	660
Air flow	m³/h	19600	22000	22000	22000
Sound levels					
Sound power level	dB-A	78	82	87	87
Sound pressure level	dB-A	50	54	59	59
Electrical data					
Main power supply	V/Ph/Hz	400/3+N/50			
Voltage permissible limit	V	360-440			
Maximum absorbed power (*)	kW	25	32	36	36.6
Maximum absorbed current (*)	A	42.8	56.3	60.4	64.8
Start-up current	A	170	185	225	225
System water content					
Minimum water content (**)	l	120	160	170	200
Maximum water content (***)	l	1500	1500	1500	1500
Dimensions & Weights					
HxWxD unit	mm	1175 x 1955 x 1050	1175 x 1955 x 1050	1175 x 1955 x 1050	1425 x 1955 x 1050
Weight unit	kg	573	607	629	679
HxWxD buffer tank (accessory)	mm	611 x 1955 x 1050	611 x 1955 x 1050	611 x 1955 x 1050	611 x 1955 x 1050
Weight buffer tank (accessory)	kg	185	185	185	185

(*) Within the operatin limits

(**) If water content of the system is below minimum the installation of a storage tank is necessary

(***) If the water volume of the system is above the maximum, an additional expansion tank is required

ESEER: European Seasonal Energy Efficiency Ratio published by Eurovent

Specifications subject to change without notice

Nominal conditions

• Outdoor air temperature	35°C
• Inlet water temperature	12°C
• Outlet water temperature	7°C

Sound pressure level

• Unit installed outdoor (free field)	
• Measuring distance	10 m
• Outdoor air temperature	35°C

OPERATING LIMITS

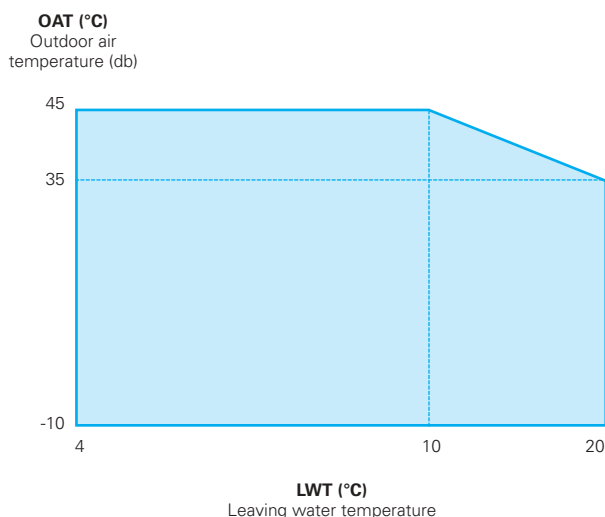

AIR-TO-WATER HEAT PUMPS

NOMINAL PERFORMANCE & PHYSICAL DATA

MODEL	SCP-AR502EH8		SCP-AR602EH8		SCP-AR702EH8		SCP-AR802EH8			
	Cooling	Heating	Cooling	Heating	Cooling	Heating	Cooling	Heating		
Performance										
Capacity	kW	40.6	49.0	52.6	54.0	60.6	69.3	65.0	76.0	
Absorbed power	kW	17.7	17.8	21.2	19.0	27.1	27.0	29.0	30.5	
Absorbed current	A	35.0	37.2	41.1	39.2	53.5	48.8	58.0	58.2	
E.E.R./C.O.P.	W/W	2.29	2.75	2.48	2.84	2.24	2.57	2.24	2.49	
ESEER	W/W	2.76	—	2.34	—	2.45	—	2.66	—	
Water flow	l/sec	1.94	2.34	2.51	2.58	2.90	3.31	3.06	3.58	
Available pump head	kPa	260	215	200	180	210	150	200	120	
Main power supply	V/Ph/Hz	400/3+N/50								
Expansion tank volume	l	18								
Hydraulic connection diameter	inch	1 1/2 Male								
Compressor	n./type	2/Hermetic SCROLL								
Refrigerant circuits	n.	2								
Refrigerant	type	R407C								
Total refrigerant charge	kg	2 x 8.0		2 x 9.0		2 x 8.5		2 x 12.5		
Fan	n./type/Ømm	2/axial flow vertical discharge/760								
Fan speed	rpm	620							660	
Air flow	m³/h	19600							22000	
Sound levels										
Sound power level	dB-A	78		76		80		85		
Sound pressure level	dB-A	50		48		52		57		
Electrical data										
Main power supply	V/Ph/Hz	400/3+N/50								
Voltage permissible limit	V	360-440								
Maximum absorbed power (*)	kW	22.8		26.4		35.8		39.0		
Maximum absorbed current (*)	A	39.6		45.8		61.2		70.6		
Start-up current	A	165		170		185		225		
System water content										
Minimum water content (**)	l	130		150		200		200		
Maximum water content (***)	l	550		550		550		550		
Dimensions & Weights										
HxWxD unit	mm	1175 x 1955 x 1050		1175 x 1955 x 1050		1175 x 1955 x 1050		1425 x 1955 x 1050		
Weight unit	kg	589		593		627		699		
HxWxD buffer tank (accessory)	mm	611 x 1955 x 1050		611 x 1955 x 1050		611 x 1955 x 1050		611 x 1955 x 1050		
Weight buffer tank (accessory)	kg	185		185		185		185		

Specifications subject to change without notice

(*) Within the operatin limits

(**) If water content of the system is below minimum the installation of a storage tank is necessary

(***) If the water volume of the system is above the maximum, an additional expansion tank is required

ESEER: European Seasonal Energy Efficiency Ratio published by Eurovent

Nominal conditions	Sound pressure level	
	Cooling	Heating
• Outdoor air temperature (db/wb)	35°C (db)	7/6°C
• Inlet water temperature	12°C	40°C
• Outlet water temperature	7°C	45°C
• Unit installed outdoor (free field)		
• Measuring distance		10 m
• Outdoor air temperature		35°C

OPERATING LIMITS

OAT (°C)
Outdoor air
temperature (db)

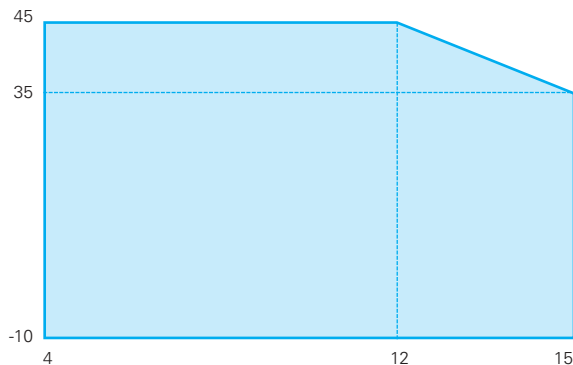

LWT (°C)
Leaving water temperature

OAT (°C)
Outdoor air
temperature (wb)

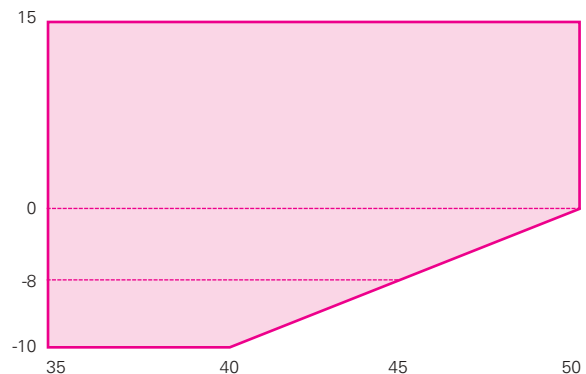

LWT (°C)
Leaving water temperature

WATER CHILLERS & HEAT PUMPS

DIMENSIONS AND MINIMUM CLEARANCE

Dimensions (in mm) are given for standard units without options.
General tolerance ± 10 mm.

WATER CHILLERS

SCP-AR502E8
SCP-AR602E8
SCP-AR702E8
SCP-AR802E8

HEAT PUMPS

SCP-AR502E8
SCP-AR602E8
SCP-AR702E8
SCP-AR802E8

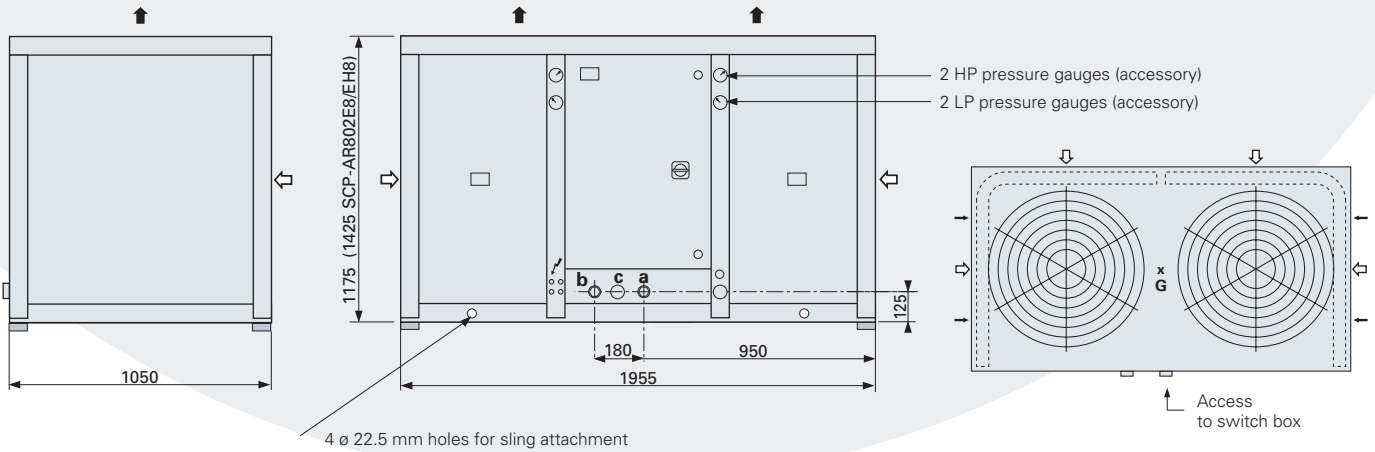

With 300-litre buffer tank (70600120 accessory)

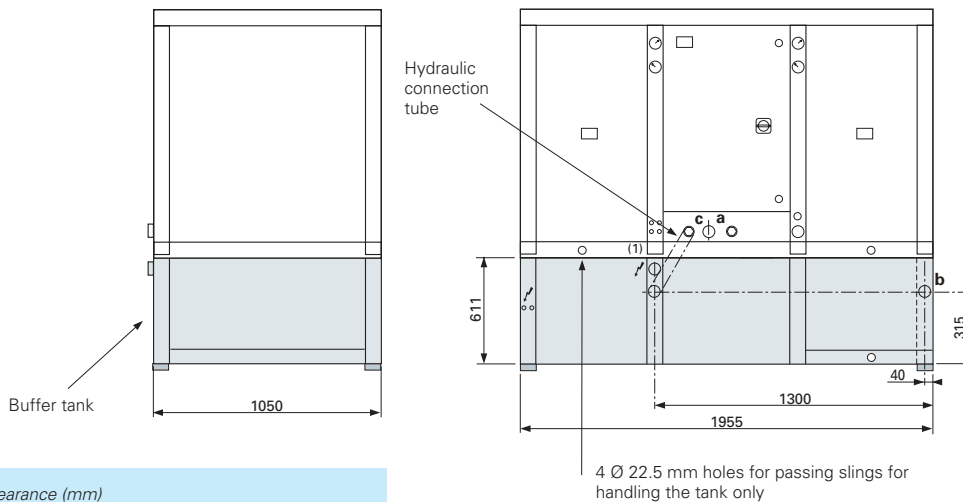

Minimum clearance (mm)

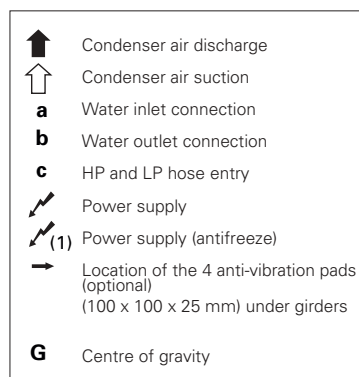
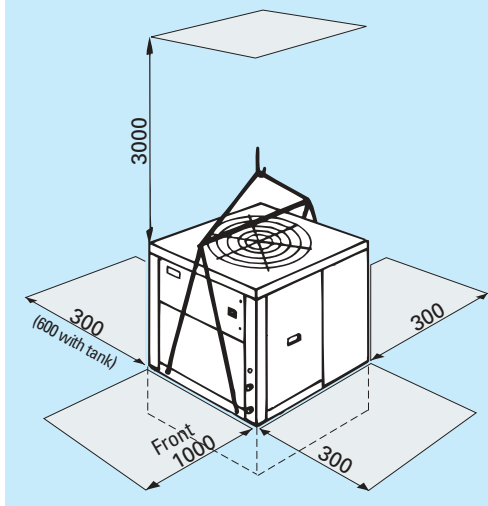

CONTROLS

Remote control



The functions and display are exactly the same as those on built-in controller. The controller is designed to be installed inside sheltered rooms. The link can be extended up to 100 meters using a twisted pair shielded cable.

- **70250055** for 071-401 models
- **70250057** for 502-802 models

RS485 ModBus Interface



- **70250056**

For connection of the electronic control to a BMS system with ModBus standard.

ACCESSORIES

Buffer tank

To be used when water content of the system is below the minimum quantity as in the specification table.

- **70600118** capacity of 35lt for 071-181 models
- **70600110** capacity of 150lt with 400W anti-freeze electric heater for 201-401 models
- **70600120** capacity of 300lt with 800W anti-freeze electric heater for 502-802 models

Set of two water hoses

With female connection.

- **70600054** length 1m Ø 3/4" for 071-091 models
- **70600055** length 1m Ø 1" for 111-181 models
- **70600027** length 1m Ø 1" 1/4 for 201-401 models
- **70600034** length 1.5m Ø 1" 1/2 for 502-802 models

Start-up kit

This kit is used to lower the start-up current of the single-phase compressors.

- **70550004** for 071EH5, 081E5, 081EH5, 091EH5, 121EH5 models

HP and LP gauges

These elements, mounted on the vertical members of the unit's front face, display the high and low pressure values for each refrigeration circuit.

- **70970006** x1pc for 201-351 models
- **70970007** x1pc for 401 model
- **70970006** x2pcs for 502-702 models
- **70970007** x2pcs for 802 model

Set of anti-vibration pads

To be located under girders.

- included, 2pcs thickness 12.5mm, for 071-181 models
- **70600035**, 4pcs thickness 25mm, for 201-802 models

Condensate tank heating cord

Length 1.5m, to be placed in the bottom of the condensate tank, close to the fin tube exchanger.

- **70200055** for 071-181EH heat pump models

WATER TERMINALS

FW-X



Ceiling cassette

FW-K



Wall mounted

FW-FT



Floor/Ceiling

Unit Size		011	021	031	041	051	061	081	101
X	CEILING CASSETTE 2 pipes								
	Total cooling (max. fan speed) kW	–	–	2.6	–	4.7	6	7.6	9.9
	MOD. for wired remote control (optional)	–	–	FW-X031EH5	–	FW-X051EH5	FW-X061EH5	FW-X081EH5	FW-X101EH5
	MOD. with infrared remote control (included)	–	–	FW-X032EH5	–	FW-X052EH5	FW-X062EH5	FW-X082EH5	FW-X102EH5
	GRILLE PANEL for unit with wired remote control	–	–	PNR-X031EHA	–	PNR-X031EHA	PNR-X061EHA	PNR-X101EHA	PNR-X101EHA
	GRILLE PANEL for unit with infrared remote control	–	–	PNR-X032EHA	–	PNR-X032EHA	PNR-X062EHA	PNR-X102EHA	PNR-X102EHA
Dimensions H/W/D	cassette mm	–	–	296x575x575	–	296x575x575	310x760x760	340x760x1050	340x760x1050
	grille panel mm	–	–	41x730x730	–	41x730x730	30x860x860	30x860x1150	30x860x1150
X	CEILING CASSETTE 4 pipes								
	Total cooling (max. fan speed) kW	–	–	2.1	–	3.8			
	MOD. for wired remote control (optional)	–	–	FW-X031EH5-4	–	FW-X051EH5-4			
	GRILLE PANEL for unit with wired remote control	–	–	PNR-X031EHA	–	PNR-X031EHA			
	Dimensions H/W/D	cassette mm	–	–	296x575x575	–	296x575x575		
	grille panel mm	–	–	41x730x730	–	41x730x730			
FT	FLOOR/CEILING UNIT 2 pipes								
	Total cooling (max. fan speed) kW	–	2.4	3.2	3.6				
	MOD. for wired remote control (optional)	–	FW-FT021EH5	FW-FT031EH5	FW-FT041EH5				
	MOD. with infrared remote control (included)	–	FW-FT022EH5	FW-FT032EH5	FW-FT042EH5				
Dimensions H/W/D	mm	–	680x900x190	680x900x190	680x900x190				
K	WALL MOUNTED UNIT 2 pipes								
	Total cooling (max. fan speed) kW	1.2	1.7	3.2	3.7				
	MOD. for wired remote control (optional)	FW-K011EH5	FW-K021EH5	FW-K031EH5	FW-K041EH5				
	MOD. with infrared remote control (included)	FW-K012EH5	FW-K022EH5	FW-K032EH5	FW-K042EH5				
Dimensions H/W/D	mm	270x805x177	270x805x177	285x995x206	285x995x206				

Specifications subject to change without notice

FAN COIL UNITS

S-VM



Vertical cabinet

S-HM



Horizontal/Vertical cabinet

S-VH

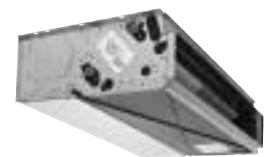

Concealed vertical/horizontal

Unit size		151	251	351	401	501	601	701	
	Cooling capacity kW	1.5	2.5	3.5	4.0	5.0	6.0	7.0	
VM	VERTICAL CABINET								
	C	Centrifugal fan model	S-VMC151-2	S-VMC251-2	S-VMC351-2	S-VMC401-2	S-VMC501-2	S-VMC601-2	S-VMC701-2
		4-pipes	S-VMC151-4	S-VMC251-4	S-VMC351-4	S-VMC401-4	S-VMC501-4	S-VMC601-4	S-VMC701-4
		Dimensions H/W/D	mm	530x775x225	530x990x225	530x1205x225	530x1205x225	530x1420x225	530x1420x255
	T	Cross flow fan model	S-VMT151-2	S-VMT251-2	S-VMT351-2				
		4-pipes	S-VMT151-4	S-VMT251-4	S-VMT351-4				
	Dimensions H/W/D	mm	530x775x225	530x990x225	530x1205x225				
HM	HORIZONTAL/VERTICAL CABINET								
	C	Centrifugal fan model	S-HMC151-2	S-HMC251-2	S-HMC351-2	S-HMC401-2	S-HMC501-2	S-HMC601-2	S-HMC701-2
		4-pipes	S-HMC151-4	S-HMC251-4	S-HMC351-4	S-HMC401-4	S-HMC501-4	S-HMC601-4	S-HMC701-4
		Dimensions H/W/D	mm	225x775x530	225x990x530	225x1205x530	225x1205x530	225x1420x530	225x1420x530
	T	Cross flow fan model	S-HMT151-2	S-HMT251-2	S-HMT351-2				
		4-pipes	S-HMT151-4	S-HMT251-4	S-HMT351-4				
	Dimensions H/W/D	mm	225x775x530	225x990x530	225x1205x530				
VH	CONCEALED VERTICAL/HORIZONTAL								
	C	Centrifugal fan model	S-VHC151-2	S-VHC251-2	S-VHC351-2	S-VHC401-2	S-VHC501-2	S-VHC601-2	S-VHC701-2
		4-pipes	S-VHC151-4	S-VHC251-4	S-VHC351-4	S-VHC401-4	S-VHC501-4	S-VHC601-4	S-VHC701-4
		Dimensions H/W/D	mm	530x510x218	530x725x218	530x940x218	530x940x218	530x1155x218	530x1155x248
	T	Cross flow fan model	S-VHT151-2	S-VHT251-2	S-VHT351-2				
		4-pipes	S-VHT151-4	S-VHT251-4	S-VHT351-4				
	Dimensions H/W/D	mm	530x567x218	530x782x218	530x1007x218				

Specifications subject to change without notice



SANYO Electric Co., Ltd.
(Japan)



ISO 9001: 2001
Certificate Number:
JQ116B



ISO 14001: 2001
Certificate Number:
ECOOJ0303-33



The European Committee of Air Handling
and Air Conditioning
Equipment Manufacturers

SANYO

SANYO Airconditioners Europe s.r.l.
Via Bisceglie, 76 - 20152 Milan - Italy
tel. +39.02.48.300.760 fax +39.02.48.300.656
www.sanyoaircond.com